

FCC RADIO TEST REPORT

FCC ID:2AWOBJR1602

Product: Remote Controler
Trade Name: N/A
Model Name: JR1602FCC
Serial Model: N/A
Report No.: UNIA20060219ER

Prepared for

DONGGUAN HOGNYUANWEI Technology Co.,LTD
155 East Central Road, Xiansha Second Industrial Zone, GaoBu Town,
Dongguan City, Guangdong Province

Prepared by

Shenzhen United Testing Technology Co., Ltd.
2F, Annex Bldg, Jiahuangyuan Tech Park, #365 Baotian 1 Rd, Tiegang
Community, Xixiang Str, Bao'an District, Shenzhen, China

TEST RESULT CERTIFICATION

Applicant's name.....: DONGGUAN HOGNYUANWEI Technology Co.,LTD
 Address.....: 155 East Central Road, Xiansha Second Industrial Zone, GaoBu
 Town, Dongguan City, Guangdong Province

Manufacture's Name.....: DONGGUAN HOGNYUANWEI Technology Co.,LTD
 Address.....: 155 East Central Road, Xiansha Second Industrial Zone, GaoBu
 Town, Dongguan City, Guangdong Province

Product description

Product name.....: Remote Controler
 Trade Mark.....: N/A
 Model and/or type reference .: JR1602FCC

Standards.....: FCC Rules and Regulations Part 15 Subpart C Section 15.249,
 ANSI C63.10: 2013

This device described above has been tested by Shenzhen United Testing Technology Co., Ltd., and the test results show that the equipment under test (EUT) is in compliance with the FCC requirements. And it is applicable only to the tested sample identified in the report.

This report shall not be reproduced except in full, without the written approval of UNI, this document may be altered or revised by Shenzhen United Testing Technology Co., Ltd., personnel only, and shall be noted in the revision of the document.

Date of Test..... :
 Date (s) of performance of tests.....: Jun. 01, 2020 - Jun. 28, 2020
 Date of Issue.....: Jun. 28, 2020
 Test Result.....: Pass

Prepared by:

Bob Liao



Bob Liao/Editor

Reviewer:

Kahn yang/Supervisor

Approved & Authorized Signer:

Liuzze

Liuzze/Manager

Table of Contents	Page
1 . TEST SUMMARY	4
2 . GENERAL INFORMATION	5
2.1 GENERAL DESCRIPTION OF EUT	5
2.2 Carrier Frequency of Channels	6
2.3 Operation of EUT during testing	6
2.4DESCRIPTION OF TEST SETUP	6
2.5MEASUREMENT INSTRUMENTS LIST	8
3 . CONDUCTED EMISSIONS TEST	9
3.1 Conducted Power Line Emission Limit	9
3.2 Test Setup	9
3.3 Test Procedure	9
3.4 Test Result	9
4 RADIATED EMISSION TEST	11
4.1 Radiation Limit	11
4.2 Test Setup	11
4.3 Test Procedure	12
4.4 Test Result	13
5 BAND EDGE	18
5.1 Limits	18
5.2 Test Procedure	18
5.3 Test Result	18
6 OCCUPIED BANDWIDTH MEASUREMENT	21
6.1 Test Setup	21
6.2 Test Procedure	21
6.3 Measurement Equipment Used	21
6.4 Test Result	21
7 ANTENNA REQUIREMENT	23
8 PHOTOGRAPH OF TEST	24
8.1 Radiated Emission	24
8.2Conducted Emission	25

1. TEST SUMMARY

TEST PROCEDURES AND RESULTS

DESCRIPTION OF TEST	RESULT	STANGARD
CONDUCTED EMISSIONS TEST	N/A	FCC Part 15.207
RADIATED EMISSION TEST	COMPLIANT	FCC Part15.209/15.249
BAND EDGE	COMPLIANT	FCC Part15.249(d)
OCCUPIED BANDWIDTH MEASUREMENT	COMPLIANT	FCC Part15.215
ANTENNA REQUIREMENT	COMPLIANT	FCC Part15.203

TEST FACILITY

Test Firm : Shenzhen United Testing Technology Co., Ltd.

Address : 2F, Annex Bldg, Jiahuangyuan Tech Park, #365 Baotian 1 Rd, Tiegang Community, Xixiang Str, Bao'an District, Shenzhen, China

The testing quality ability of our laboratory meet with "Quality Law of People's Republic of China" Clause 19. The testing quality system of our laboratory meets with ISO/IEC-17025 requirements. This approval result is accepted by MRA of APLAC.

Our test facility is recognized, certified, or accredited by the following organizations:

A2LA Certificate Number: 4747.01

The EMC Laboratory has been accredited by A2LA, and in compliance with ISO/IEC 17025:2017 General Requirements for testing Laboratories.

FCC Registration Number: 674885

The EMC Laboratory has been registered and fully described in a report filed with the (FCC) Federal Communications commission.

IC Registration Number: 21947

The EMC Laboratory has been registered and fully described in a report filed with the (IC) Industry Canada.

MEASUREMENT UNCERTAINTY

Measurement Uncertainty

Conducted Emission Expanded Uncertainty	=	2.23dB, k=2
Radiated emission expanded uncertainty(9kHz-30MHz)	=	3.08dB, k=2
Radiated emission expanded uncertainty(30MHz-1000MHz)	=	4.42dB, k=2
Radiated emission expanded uncertainty(Above 1GHz)	=	4.06dB, k=2

2. GENERAL INFORMATION

2.1 GENERAL DESCRIPTION OF EUT

Equipment	Remote Controler
Trade Mark	N/A
Model Name	JR1602FCC
Serial No.	N/A
Model Difference	N/A
Antenna Type	PCB antenna
Antenna Gain	0 dBi
Frequency Range	2407~2473MHz
Number of Channels	67CH
Modulation Type	GFSK
Battery	N/A
PowerSource	DC 3V by 2*1.5V AAA Battery

2.2 Carrier Frequency of Channels

Channel List							
Channel	Frequency (MHz)	Channel	Frequency (MHz)	Channel	Frequency (MHz)	Channel	Frequency (MHz)
00	2407	21	2428	42	2449	63	2470
01	2408	22	2429	43	2450	64	2471
02	2409	23	2430	44	2451	65	2472
03	2410	24	2431	45	2452	66	2473
04	2411	25	2432	46	2453		
05	2412	26	2433	47	2454		
06	2413	27	2434	48	2455		
07	2414	28	2435	49	2456		
08	2415	29	2436	50	2457		
09	2416	30	2437	51	2458		
10	2417	31	2438	52	2459		
11	2418	32	2439	53	2460		
12	2419	33	2440	54	2461		
13	2420	34	2441	55	2462		
14	2421	35	2442	56	2463		
15	2422	36	2443	57	2464		
16	2423	37	2444	58	2465		
17	2424	38	2445	59	2466		
18	2425	39	2446	60	2467		
19	2426	40	2447	61	2468		
20	2427	41	2448	62	2469		

2.3 Operation of EUT during testing

Operating Mode

The mode is used: Transmitting mode

Low Channel: 2407MHz

Middle Channel: 2440MHz

High Channel: 2473MHz

2.4 DESCRIPTION OF TEST SETUP

Operation of EUT during Conducted testing:



Operation of EUT during Radiation testing:



Table for auxiliary equipment:

Equipment Description	Manufacturer	Model	Calibration Due Date
N/A	N/A	N/A	N/A

2.5 MEASUREMENT INSTRUMENTS LIST

Item	Equipment	Manufacturer	Model No.	Serial No.	Calibrated until
CONDUCTED EMISSIONS TEST					
1	AMN	Schwarzbeck	NNLK8121	8121370	2020.09.06
2	AMN	ETS	3810/2	00020199	2020.09.06
3	EMI TEST RECEIVER	Rohde&Schwarz	ESCI	101210	2020.09.06
4	AAN	TESEQ	JR1602FCC/JR1630RX-Cat6	38888	2020.09.06
RADIATED EMISSION TEST					
1	Horn Antenna	Sunol	DRH-118	A101415	2020.09.06
2	BicoNILog Antenna	Sunol	JB1 Antenna	A090215	2020.09.06
3	PREAMP	HP	8449B	3008A00160	2020.09.06
4	PREAMP	HP	8447D	2944A07999	2020.09.06
5	EMI TEST RECEIVER	Rohde&Schwarz	ESR3	101891	2020.09.06
6	VECTOR Signal Generator	Rohde&Schwarz	SMU200A	101521	2020.09.06
7	Signal Generator	Agilent	E4421B	MY4335105	2020.09.06
8	MXA Signal Analyzer	Agilent	N9020A	MY50510140	2020.09.06
9	MXA Signal Analyzer	Agilent	N9020A	MY51110104	2020.09.06
10	ANT Tower&Turn table Controller	Champro	EM 1000	60764	2020.09.06
11	Anechoic Chamber	Taihe Maorui	9m*6m*6m	966A0001	2020.09.06
12	Shielding Room	Taihe Maorui	6.4m*4m*3m	643A0001	2020.09.06
13	RF Power sensor	DARE	RPR3006W	15I00041SNO88	2021.3.14
14	RF Power sensor	DARE	RPR3006W	15I00041SNO89	2021.3.14
15	RF power divider	Anritsu	K241B	992289	2020.09.06
16	Wideband radio communication tester	Rohde&Schwarz	CMW500	154987	2020.09.06
17	Biconical antenna	Schwarzbeck	VHA 9103	91032360	2020.09.06
18	Biconical antenna	Schwarzbeck	VHA 9103	91032361	2020.09.06
19	Broadband Hybrid Antennas	Schwarzbeck	VULB9163	VULB9163#958	2020.09.06
20	Horn Antenna	Schwarzbeck	BBHA9120D	9120D-1680	2021.1.12
21	Active Receive Loop Antenna	Schwarzbeck	FMZB 1919B	00023	2020.11.02
22	Horn Antenna	Schwarzbeck	BBHA 9170	BBHA9170651	2021.03.14
23	Microwave Broadband Preamplifier	Schwarzbeck	BBV 9721	100472	2020.09.06
24	Active Loop Antenna	Com-Power	AL-130R	10160009	2021.05.10
25	Power Meter	KEYSIGHT	N1911A	MY50520168	2021.05.10
26	Frequency Meter	VICTOR	VC2000	997406086	2021.05.10
27	DC Power Source	HYELEC	HY5020E	055161818	2021.05.10

3. CONDUCTED EMISSIONS TEST

3.1 Conducted Power Line Emission Limit

For unintentional device, according to § 15.107(a) Line Conducted Emission Limits is as following

Frequency (MHz)	Maximum RF Line Voltage(dB μ V)			
	CLASS A		CLASS B	
	Q.P.	Ave.	Q.P.	Ave.
0.15~0.50	79	66	66~56*	56~46*
0.50~5.00	73	60	56	46
5.00~30.0	73	60	60	50

* Decreasing linearly with the logarithm of the frequency

For intentional device, according to §15.207(a) Line Conducted Emission Limit is same as above table.

3.2 Test Setup

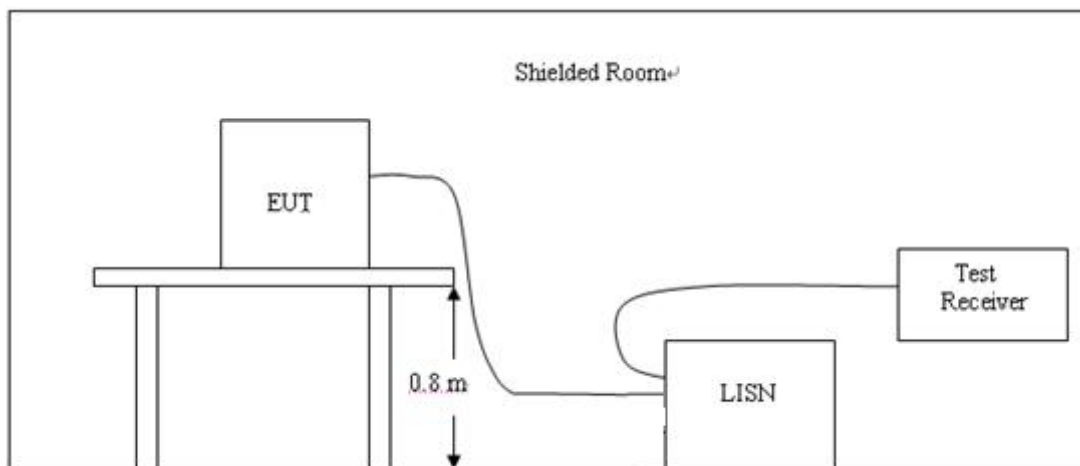

3.3 Test Procedure

- 1, The equipment was set up as per the test configuration to simulate typical actual usage per the user's manual. The EUT is a tabletop system, a wooden table with a height of 0.8 meters is used and is placed on the ground plane as per ANSI C63.10.
- 2, Support equipment, if needed, was placed as per ANSI C63.10.
- 3, All I/O cables were positioned to simulate typical actual usage as per ANSI C63.10.
- 4, If a EUT received DC power from the USB Port of Notebook PC, the PC's adapter received AC120V/60Hz power through a Line Impedance Stabilization Network (LISN) which supplied power source and was grounded to the ground plane.
- 5, All support equipments received AC power from a second LISN, if any.
- 6, The EUT test program was started. Emissions were measured on each current carrying line of the EUT using a spectrum Analyzer / Receiver connected to the LISN powering the EUT. The LISN has two monitoring points: Line 1 (Hot Side) and Line 2 (Neutral Side). Two scans were taken: one with Line 1 connected to Analyzer / Receiver and Line 2 connected to a 50 ohm load; the second scan had Line 1 connected to a 50 ohm load and Line 2 connected to the Analyzer / Receiver.
- 7, Analyzer / Receiver scanned from 150 KHz to 30MHz for emissions in each of the test modes.

3.4 Test Result

N/A

Temperature:	24°C	Relative Humidity:	45%
Test Date:	N/A	Pressure:	N/A
Test Voltage:	N/A	Phase:	N/A
Test Mode:	N/A		

4 RADIATED EMISSION TEST

4.1 Radiation Limit

For unintentional device, according to § 15.109(a), except for Class A digital devices, the field strength of radiated emissions from unintentional radiators at a distance of 3 meters shall not exceed the following values:

Limit calculation and transfer to 3m distance as showed in the following table:

Frequency (MHz)	Limit (dBuV/m)	Distance (m)
0.009-0.490	$20\log(2400/F(\text{KHz}))+40\log(300/3)$	3
0.490-1.705	$20\log(24000/F(\text{KHz}))+40\log(30/3)$	3
1.705-30.0	69.5	3
30-88	40.0	3
88-216	43.5	3
216-960	46.0	3
Above 960	54.0	3

For intentional device, according to § 15.209(a), the general requirement of field strength of radiated emissions from intentional radiators at a distance of 3 meters shall not exceed the above table.

(a) Except as provided in paragraph (b) of this section, the field strength of emissions from intentional radiators operated within these frequency bands shall comply with the following:

Fundamental frequency	Field strength of fundamental (millivolts/meter)	Field strength of harmonics (microvolts/meter)
902-928 MHz	50	500
2400-2483.5 MHz	50	500
5725-5875 MHz	50	500
24.0-24.25 GHz	250	2500

For intentionally used equipment, the general requirements for the magnetic field strength limits of the fundamental and harmonic radiation from the intentional radiator at a distance of 3 meters shall not exceed the above table, as specified in § 15.249(a).

4.2 Test Setup

1. Radiated Emission Test-Up Frequency Below 30MHz

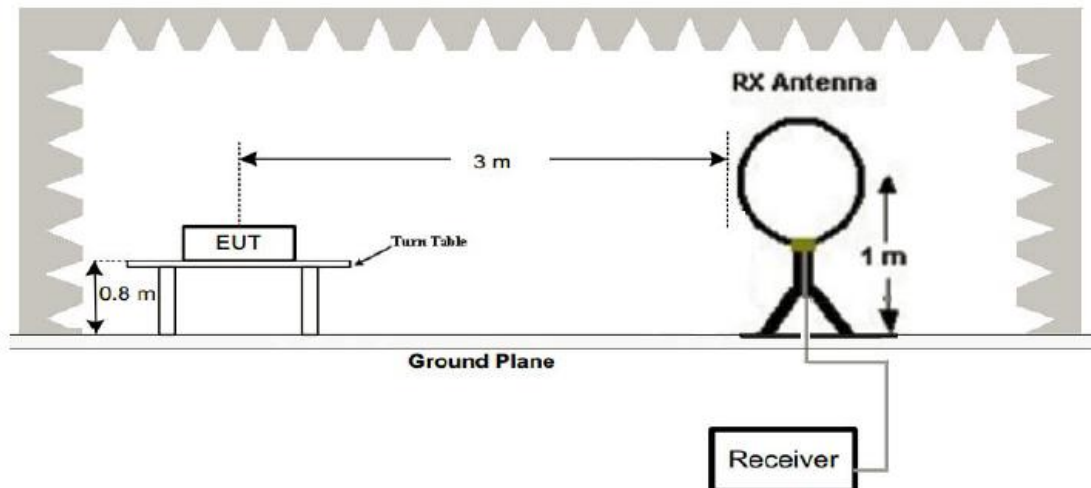

2. Radiated Emission Test-Up Frequency 30MHz~1GHz

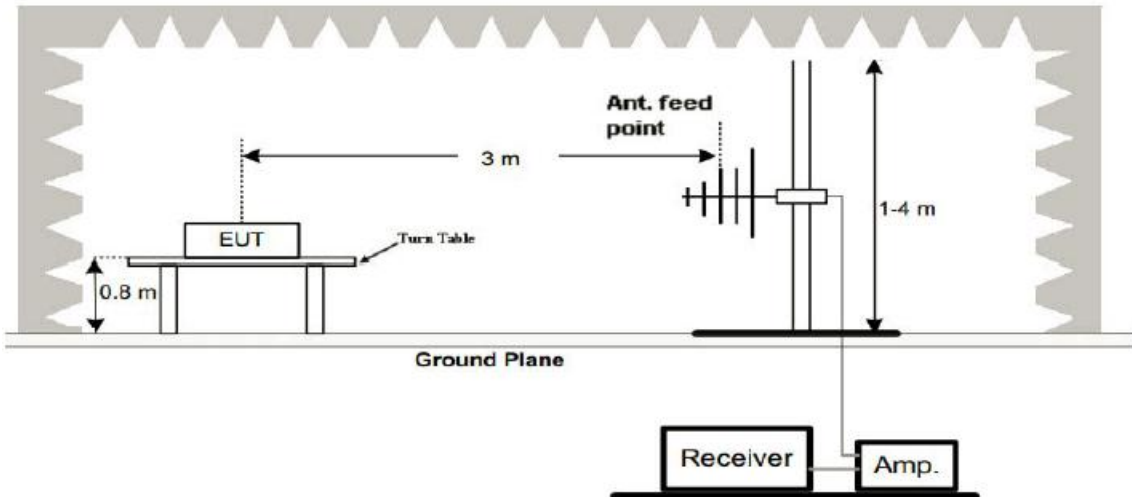

3. Radiated Emission Test-Up Frequency Above 1GHz

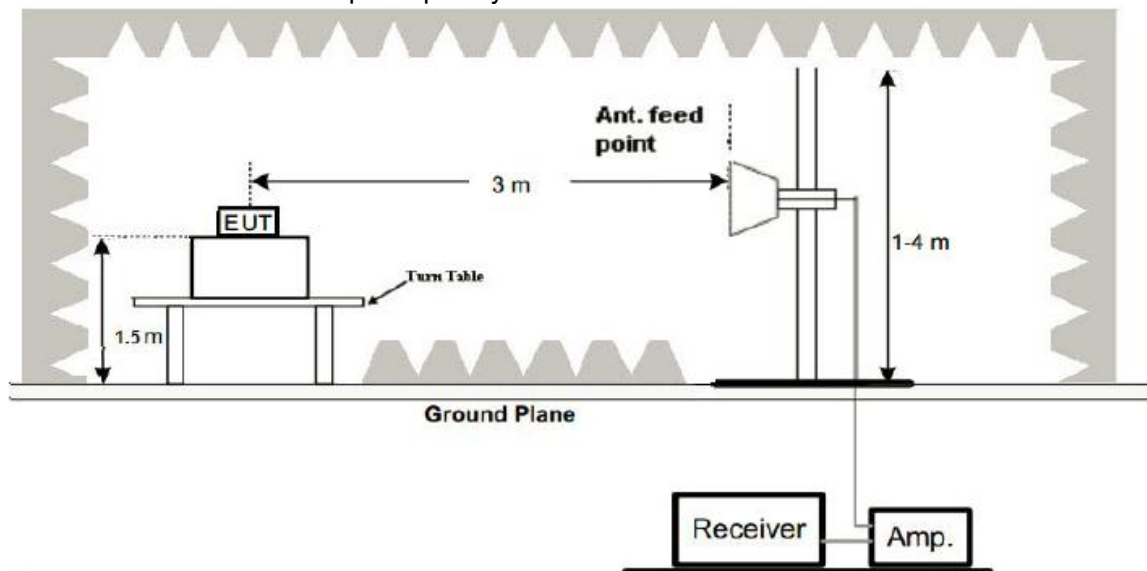

4.3 Test Procedure

1. Below 1GHz measurement the EUT is placed on turntable which is 0.8m above ground plane. And above 1GHz measurement EUT was placed on low permittivity and low tangent turn table which is 1.5m above ground plane.
2. The turntable shall be rotated for 360 degrees to determine the position of maximum emission level.
3. EUT is set 3m away from the receiving antenna, which is varied from 1m to 4m to find out the highest emissions.
4. Maximum procedure was performed on the six highest emissions to ensure EUT compliance.
5. And also, each emission was to be maximized by changing the polarization of receiving antenna both horizontal and vertical.
6. Repeat above procedures until the measurements for all frequencies are complete.
7. The test frequency range from 9KHz to 25GHz per FCC PART 15.33(a).

Note:

For battery operated equipment, the equipment tests shall be performed using a new battery.

4.4 Test Result

PASS

Remark:

1. All the test modes completed for test. The worst case of Radiated Emission is High channel, the test data of this mode was reported.
2. By preliminary testing and verifying three axis (X, Y and Z) position of EUT transmitted status, it was found that "Z axis" position was the worst, and test data recorded in this report.
3. Radiated emission test from 9KHz to 10th harmonic of fundamental was verified, and no emission found except system noise floor in 9KHz to 30MHz and not recorded in this report.

Below 1GHz Test Results:

Temperature:	24°C	Relative Humidity:	45%
Test Date:	Jun.12,2020	Pressure:	1010hPa
Test Voltage:	DC 3V	Polarization:	Horizontal
Test Mode:	Transmitting mode of GFSK2473MHz		

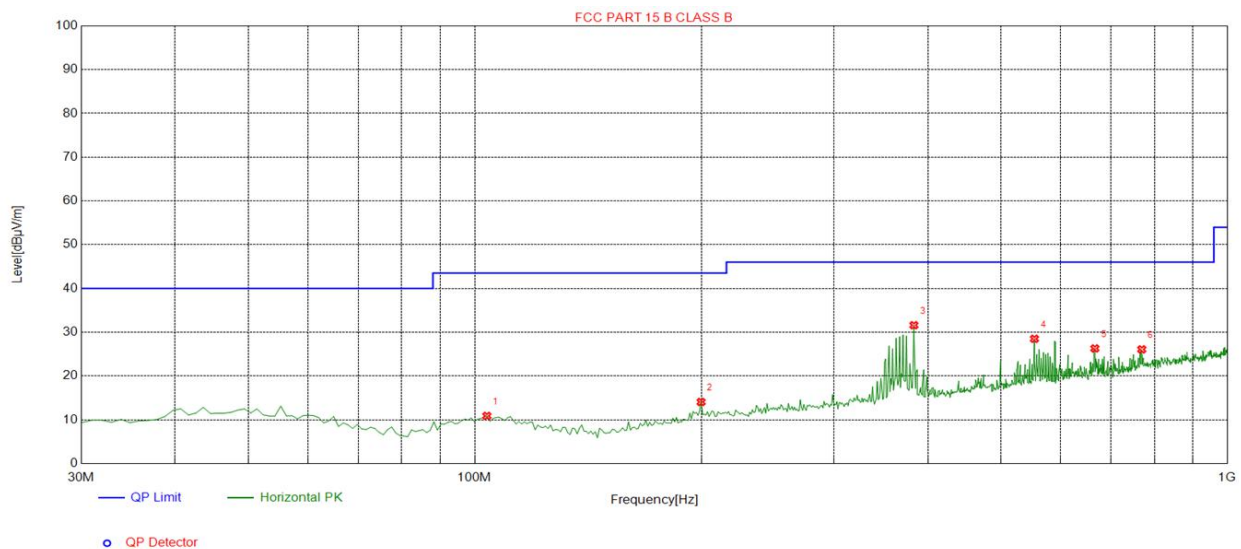

Suspected List									
NO.	Freq. [MHz]	Factor [dB]	Reading [dBµV/m]	Level [dBµV/m]	Limit [dBµV/m]	Margin [dB]	Height [cm]	Angle [°]	Polarity
1	103.7938	-15.41	26.28	10.87	43.50	32.63	100	329	Horizontal
2	199.9199	-15.07	29.13	14.06	43.50	29.44	100	254	Horizontal
3	383.4334	-10.76	42.36	31.60	46.00	14.40	100	178	Horizontal
4	554.3243	-6.84	35.33	28.49	46.00	17.51	100	25	Horizontal
5	666.9570	-4.75	31.04	26.29	46.00	19.71	100	322	Horizontal
6	769.8799	-3.25	29.32	26.07	46.00	19.93	100	303	Horizontal

Remark: Absolute Level= Reading Level+ Factor, Margin= Absolute Level – Limit
 Factor=Ant. Factor + Cable Loss – Pre-amplifier

Temperature:	24°C	Relative Humidity:	45%
Test Date:	Jun.12,2020	Pressure:	1010hPa
Test Voltage:	DC 3V	Polarization:	Vertical
Test Mode:	Transmitting mode of GFSK2473MHz		

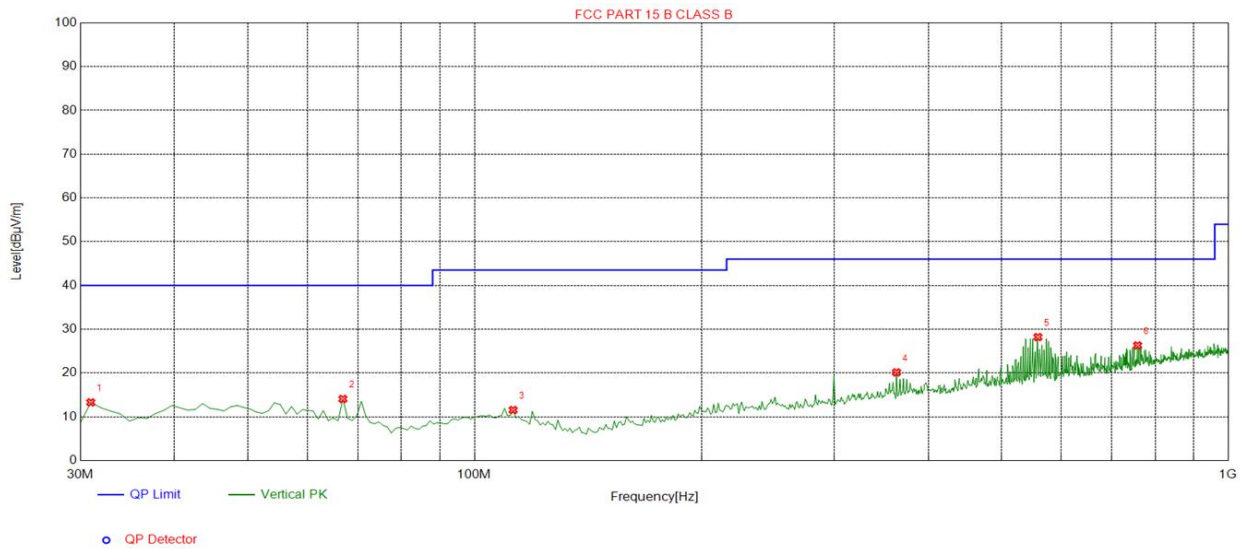

Suspected List									
NO.	Freq. [MHz]	Factor [dB]	Reading [dBµV/m]	Level [dBµV/m]	Limit [dBµV/m]	Margin [dB]	Height [cm]	Angle [°]	Polarity
1	30.9710	-16.30	29.57	13.27	40.00	26.73	100	297	Vertical
2	66.8969	-16.89	30.95	14.06	40.00	25.94	100	73	Vertical
3	112.5325	-15.85	27.38	11.53	43.50	31.97	100	338	Vertical
4	363.0430	-11.24	31.37	20.13	46.00	25.87	100	131	Vertical
5	559.1792	-6.70	34.90	28.20	46.00	17.80	100	12	Vertical
6	758.2282	-3.53	29.83	26.30	46.00	19.70	100	22	Vertical

Remark: Absolute Level= Reading Level+ Factor, Margin= Absolute Level – Limit
Factor=Ant. Factor + Cable Loss – Pre-amplifier

Remark:

- (1) Measuring frequencies from 9 KHz to the 1 GHz, Radiated emission test from 9KHz to 30MHz was verified, and no any emission was found except system noise floor.
- (2) * denotes emission frequency which appearing within the Restricted Bands specified in provision of 15.205, then the general radiated emission limits in 15.209 apply.
- (3) The IF bandwidth of EMI Test Receiver between 30MHz to 1GHz was 120KHz, 1 MHz for measuring above 1 GHz, below 30MHz was 10KHz.

Above 1 GHz Test Results:
CH Low (2407MHz)

Horizontal:

Frequency (MHz)	Reading Result (dB μ V)	Factor (dB)	Emission Level (dB μ V/m)	Limits (dB μ V/m)	Margin (dB)	Detector Type
2407	105.24	-5.84	99.4	114	-14.6	PK
2407	86.43	-5.84	80.59	94	-13.41	AV
4814	55.26	-3.64	51.62	74	-22.38	PK
4814	45.79	-3.64	42.15	54	-11.85	AV
7221	54.74	-0.95	53.79	74	-20.21	PK
7221	45.38	-0.95	44.43	54	-9.57	AV

Remark: Factor = Antenna Factor + Cable Loss – Pre-amplifier. Margin= Absolute Level – Limit

Vertical:

Frequency (MHz)	Reading Result (dB μ V)	Factor (dB)	Emission Level (dB μ V/m)	Limits (dB μ V/m)	Margin (dB)	Detector Type
2407	104.68	-5.84	98.84	114	-15.16	PK
2407	85.32	-5.84	79.48	94	-14.52	AV
4814	54.19	-3.64	50.55	74	-23.45	PK
4814	45.26	-3.64	41.62	54	-12.38	AV
7221	54.39	-0.95	53.44	74	-20.56	PK
7221	45.08	-0.95	44.13	54	-9.87	AV

Remark: Factor = Antenna Factor + Cable Loss – Pre-amplifier. Margin= Absolute Level – Limit

Note:For fundamental frequency, RBW and VBW set to be 1.5MHz , PK detector for PK value , RMS detector for AV value

CH Middle (2440MHz)

Horizontal:

Frequency	Reading Result	Factor	Emission Level	Limits	Margin	Detector
(MHz)	(dB μ V)	(dB)	(dB μ V/m)	(dB μ V/m)	(dB)	Type
2440	102.39	-5.71	96.68	114	-17.32	PK
2440	84.23	-5.71	78.52	94	-15.48	AV
4880	53.69	-3.51	50.18	74	-23.82	PK
4880	45.71	-3.51	42.2	54	-11.8	AV
7200	54.28	-0.82	53.46	74	-20.54	PK
7200	45.36	-0.82	44.54	54	-9.46	AV

Remark: Factor = Antenna Factor + Cable Loss – Pre-amplifier. Margin = Absolute Level – Limit

Vertical:

Frequency	Reading Result	Factor	Emission Level	Limits	Margin	Detector
(MHz)	(dB μ V)	(dB)	(dB μ V/m)	(dB μ V/m)	(dB)	Type
2440	101.39	-5.71	95.68	114	-18.32	PK
2440	84.52	-5.71	78.81	94	-15.19	AV
4880	54.68	-3.51	51.17	74	-22.83	PK
4880	45.37	-3.51	41.86	54	-12.14	AV
7200	55.03	-0.82	54.21	74	-19.79	PK
7200	45.81	-0.82	44.99	54	-9.01	AV

Remark: Factor = Antenna Factor + Cable Loss – Pre-amplifier. Margin= Absolute Level – Limit

Note:For fundamental frequency, RBW and VBW set to be 1.5MHz , PK detector for PK value , RMS detector for AV value

CH High (2473MHz)

Horizontal:

Frequency	Reading Result	Factor	Emission Level	Limits	Margin	Detector
(MHz)	(dB μ V)	(dB)	(dB μ V/m)	(dB μ V/m)	(dB)	Type
2473	101.47	-5.65	95.82	114	-18.18	PK
2473	83.24	-5.65	77.59	94	-16.41	AV
4946	54.13	-3.43	50.7	74	-23.3	PK
4946	45.29	-3.43	41.86	54	-12.14	AV
7419	54.76	-0.75	54.01	74	-19.99	PK
7419	44.32	-0.75	43.57	54	-10.43	AV

Remark: Factor = Antenna Factor + Cable Loss – Pre-amplifier. Margin= Absolute Level – Limit

Vertical:

Frequency	Reading Result	Factor	Emission Level	Limits	Margin	Detector
(MHz)	(dB μ V)	(dB)	(dB μ V/m)	(dB μ V/m)	(dB)	Type
2473	100.34	-5.65	94.69	114	-19.31	PK
2473	82.46	-5.65	76.81	94	-17.19	AV
4946	54.03	-3.43	50.6	74	-23.4	PK
4946	45.87	-3.43	42.44	54	-11.56	AV
7419	55.03	-0.75	54.28	74	-19.72	PK
7419	45.36	-0.75	44.61	54	-9.39	AV

Remark: Factor = Antenna Factor + Cable Loss – Pre-amplifier. Margin= Absolute Level – Limit

Note:For fundamental frequency, RBW and VBW set to be 1.5MHz , PK detector for PK value , RMS detector for AV value

Remark:

- (1) Measuring frequencies from 1 GHz to the 25 GHz.
- (2) "F" denotes fundamental frequency; "H" denotes spurious frequency. "E" denotes band edge frequency.
- (3) * denotes emission frequency which appearing within the Restricted Bands specified in provision of 15.205, then the general radiated emission limits in 15.209 apply.
- (4) Data of measurement within this frequency range ,that the value more than 20dB below limit is not record in the form.
- (5) The IF bandwidth of EMI Test Receiver between 30MHz to 1GHz was 120KHz, 1 MHz for measuring above 1 GHz, below 30MHz was 10KHz.The resolution bandwidth of test receiver/spectrum analyzer is 1MHzand video bandwidth is 3MHz for peak measurement with peak detectorat frequency above 1GHz.The resolution bandwidth of test receiver/spectrum analyzer is 1MHzand video bandwidth is 10Hz for Average measurement with peak detection at frequency above 1GHz.
- (6) When the test results of Peak Detected below the limits of Average Detected, the Average Detected is not need completed. For example: Top Channel at Fundamental 73.16dBuV/m(PK Value) <93.98(AV Limit), at harmonic 53.20 dBuV/m(PK Value) <54 dBuV/m(AV Limit), the Average Detected not need to completed.
- (7)All modes of operation were investigated and the worst-case emissionsare reported.

5 BAND EDGE

5.1 Limits

FCC PART 15.249(d) Emissions radiated outside of the specified frequency bands, except for harmonics, shall be attenuated by at least 50 dB below the level of the fundamental or to the general radiated emission limits in §15.209, whichever is the lesser attenuation.

5.2 Test Procedure

The band edge compliance of RF radiated emission should be measured by following the guidance in ANSIC63.10 with respect to maximizing the emission by rotating the EUT, measuring the emission while the EUT is situated in three orthogonal planes (if appropriate), adjusting the measurement antenna height and polarization etc. Set RBW to 100KHz and VBM to 300KHz to measure the peak field strength and set RBW to 1MHz and VBW to 10Hz to measure the average radiated field strength. The conducted RF band edge was measured by using a spectrum analyzer. Set span wide enough to capture the highest in-band emission and the emission at the band edge. Set RBW to 100 KHz and VBW to 300 KHz, to measure the conducted peak band edge.

5.3 Test Result

PASS

Radiated Band Edge Test:

Operation Mode: TX CH Low (2407MHz)

Horizontal:

Frequency (MHz)	Reading Result (dBμV)	Factor (dB)	Emission Level (dBμV/m)	Limits (dBμV/m)	Margin (dB)	Detector Type
2310	53.67	-5.81	47.86	74	-26.14	PK
2310	44.12	-5.81	38.31	54	-15.69	AV
2390	54.27	-5.84	48.43	74	-25.57	PK
2390	45.38	-5.84	39.54	54	-14.46	AV
2400	55.12	-5.84	49.28	74	-24.72	PK
2400	45.04	-5.84	39.2	54	-14.80	AV

Remark: Factor = Antenna Factor + Cable Loss – Pre-amplifier.

Vertical:

Frequency (MHz)	Reading Result (dBμV)	Factor (dB)	Emission Level (dBμV/m)	Limits (dBμV/m)	Margin (dB)	Detector Type
2310	54.13	-5.81	48.32	74	-25.68	PK
2310	44.52	-5.81	38.71	54	-15.29	AV
2390	54.76	-5.84	48.92	74	-25.08	PK
2390	44.92	-5.84	39.08	54	-14.92	AV
2400	54.86	-5.84	49.02	74	-24.98	PK
2400	45.97	-5.84	40.13	54	-13.87	AV

Remark: Factor = Antenna Factor + Cable Loss – Pre-amplifier.

Operation Mode: TX CH High (2473MHz)

Horizontal:

Frequency	Reading Result	Factor	Emission Level	Limits	Margin	Detector Type
(MHz)	(dB μ V)	(dB)	(dB μ V/m)	(dB μ V/m)	(dB)	
2483.5	54.27	-5.65	48.62	74	-25.38	PK
2483.5	46.32	-5.65	40.67	54	-13.33	AV
2500	53.96	-5.72	48.24	74	-25.76	PK
2500	46.71	-5.72	40.99	54	-13.01	AV
Remark: Factor = Antenna Factor + Cable Loss – Pre-amplifier.						

Vertical:

Frequency	Reading Result	Factor	Emission Level	Limits	Margin	Detector Type
(MHz)	(dB μ V)	(dB)	(dB μ V/m)	(dB μ V/m)	(dB)	
2483.5	54.34	-5.65	48.69	74	-25.31	PK
2483.5	45.19	-5.65	39.54	54	-14.46	AV
2500	54.76	-5.72	49.04	74	-24.96	PK
2500	45.65	-5.72	39.93	54	-14.07	AV
Remark: Factor = Antenna Factor + Cable Loss – Pre-amplifier.						

2407

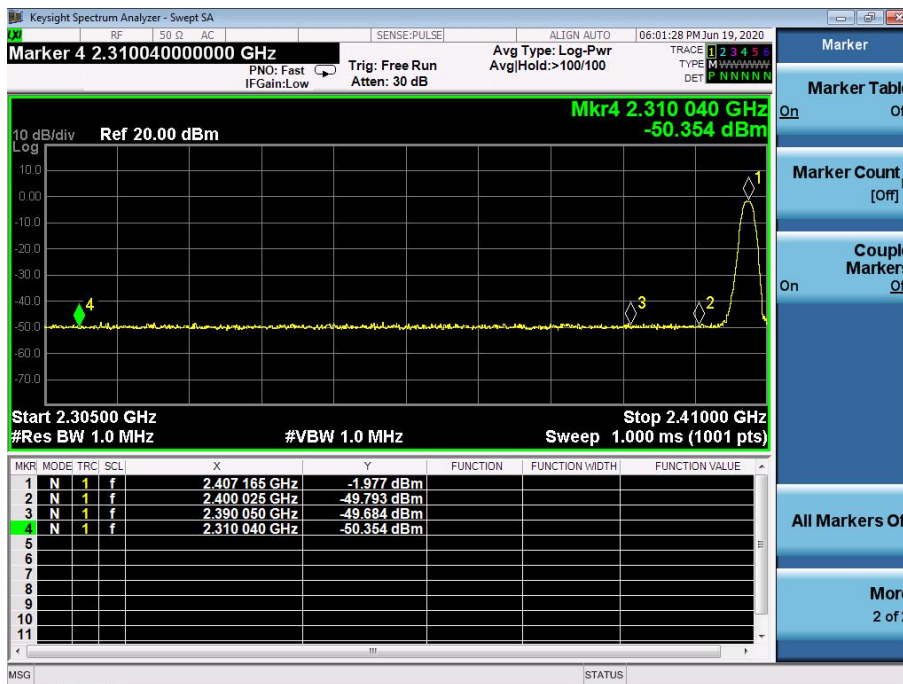

2473

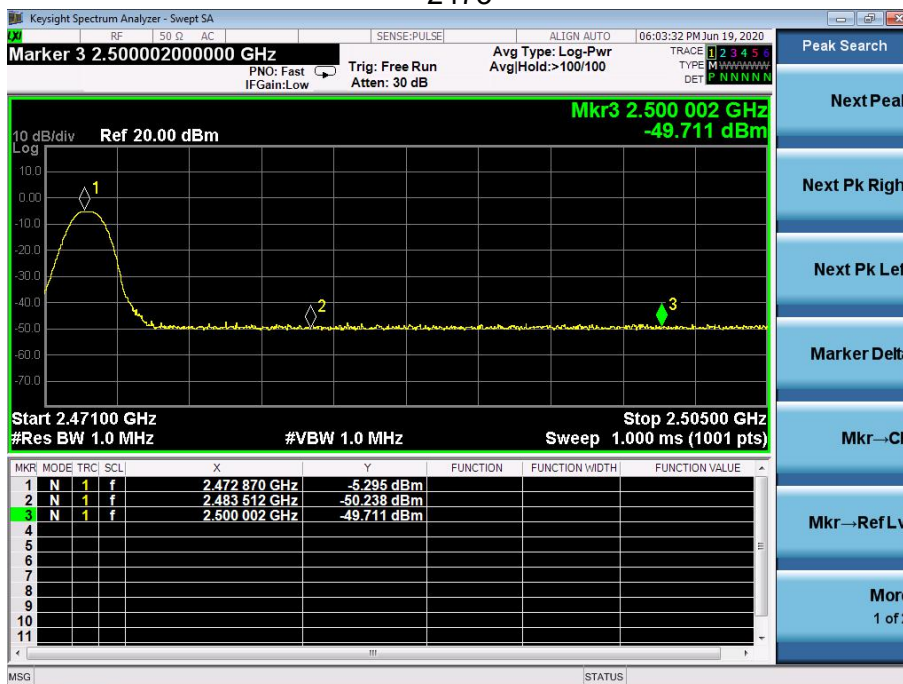

6 OCCUPIED BANDWIDTH MEASUREMENT

6.1 Test Setup

Same as Radiated Emission Measurement

6.2 Test Procedure

1. The EUT was placed on a turn table which is 0.8m above ground plane.
2. Set EUT as normal operation.
3. Based on ANSI C63.10 section 6.9.2: RBW=100KHz. VBW=100KHz, Span=10MHz.
4. The useful radiated emission from the EUT was detected by the spectrum analyzer with peak detector.

6.3 Measurement Equipment Used

Same as Radiated Emission Measurement

6.4 Test Result

PASS

Frequency (MHz)	99% Bandwidth (MHz)	Result
2407	1.1682	PASS
2440	1.1430	PASS
2473	1.1414	PASS

CH:2407MHz

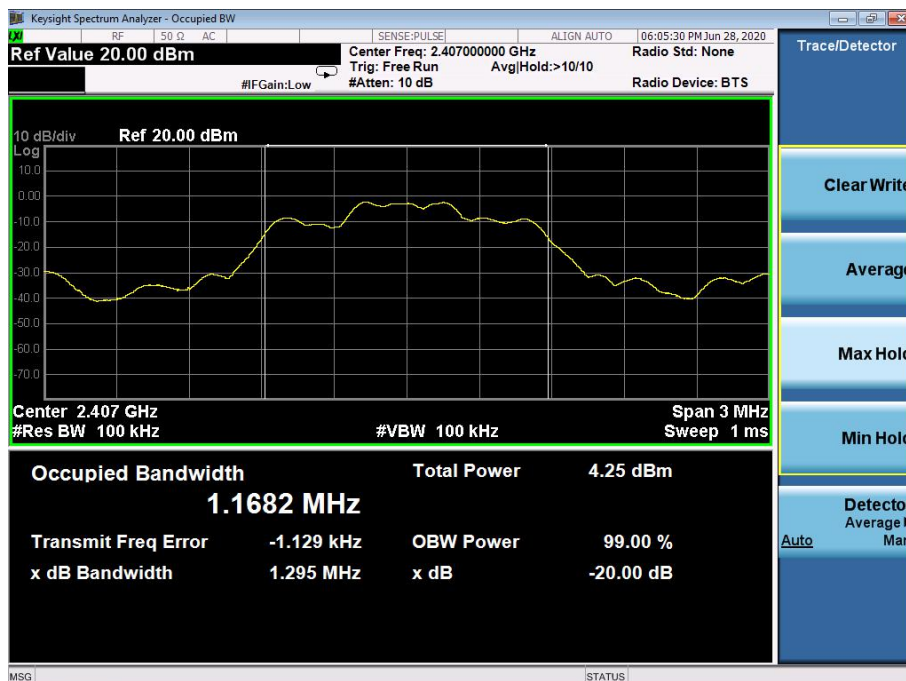

CH:2440MHz

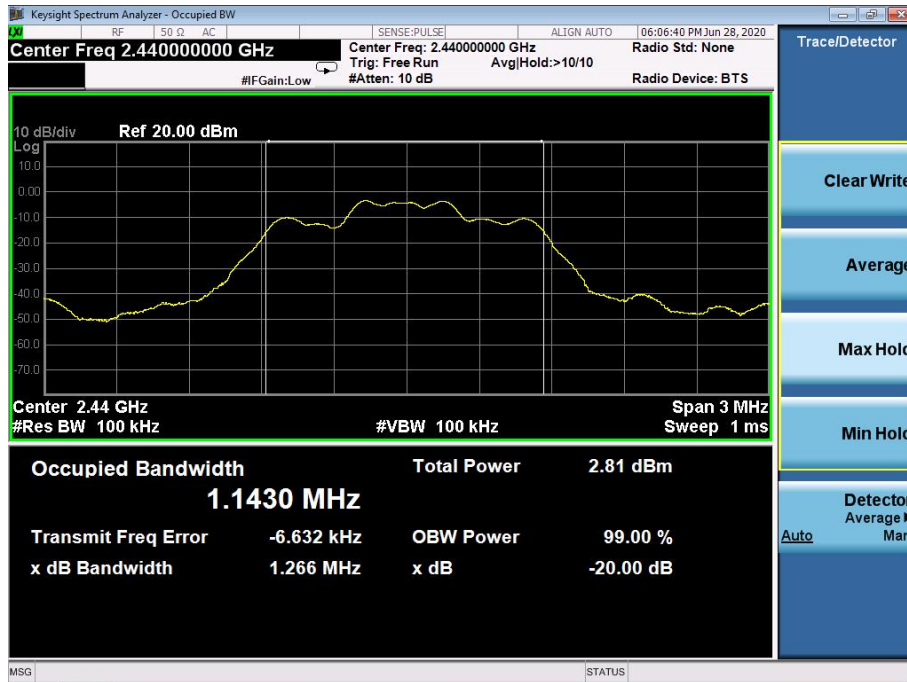

CH:2473MHz

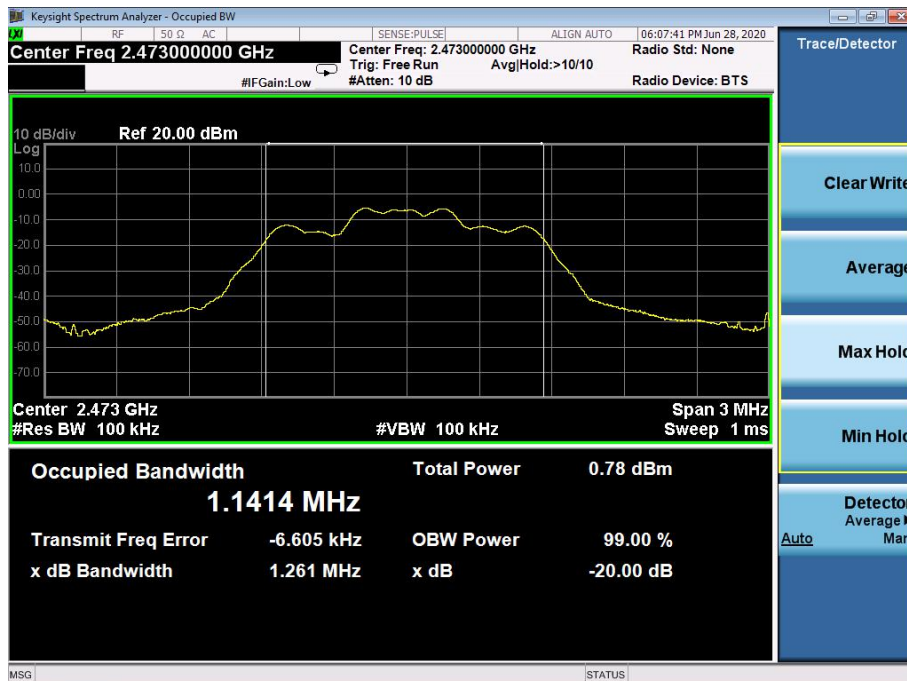

7 ANTENNA REQUIREMENT

Standard Applicable:

For intentional device, according to FCC 47 CFR Section 15.203, an intentional radiator shall be designed to ensure that no antenna other than that furnished by the responsible party shall be used with the device.

Antenna Connected Construction

The antenna used in this product is a PCB antenna, The directional gains of antenna used for transmitting is 0 dBi.

ANTENNA:

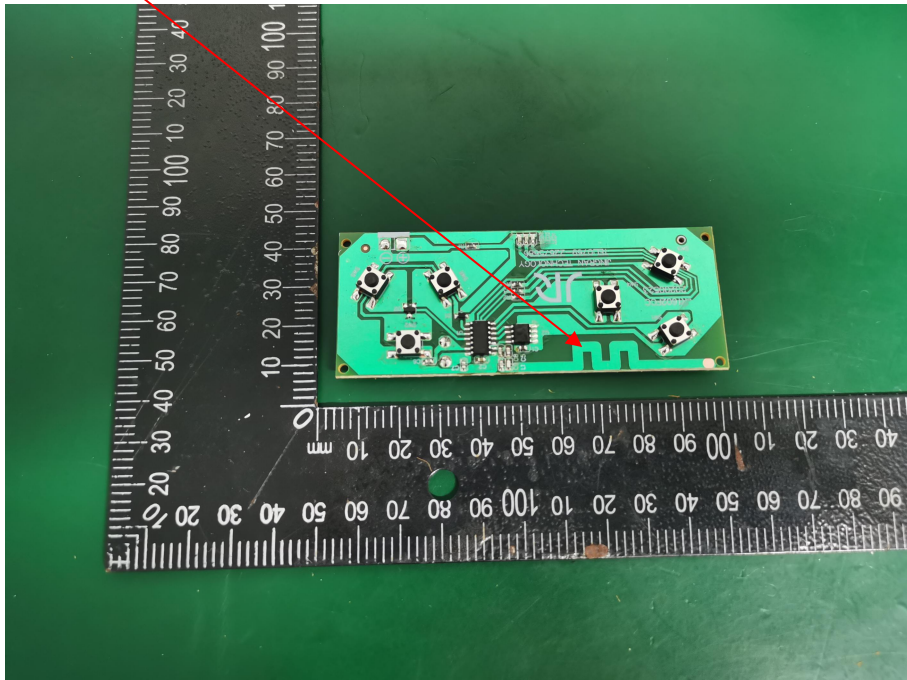

8 PHOTOGRAPH OF TEST

8.1 Radiated Emission

RE

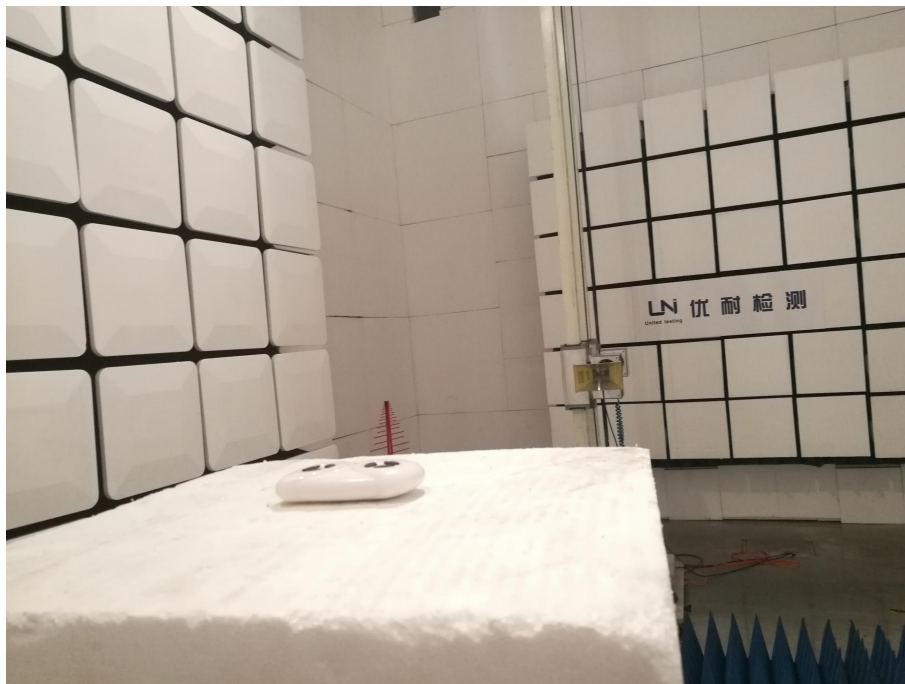
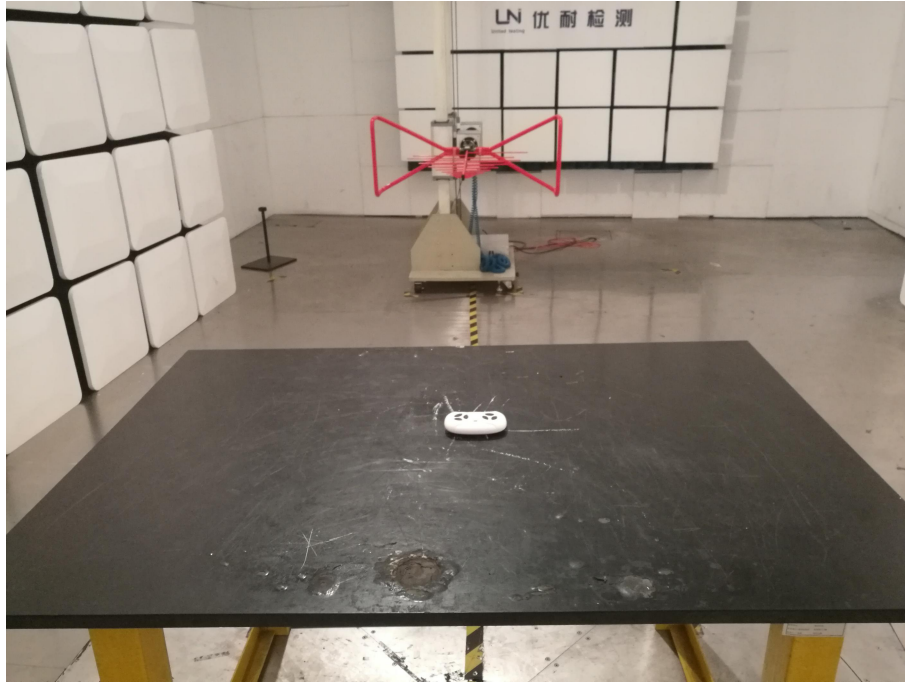

8.2 EUT

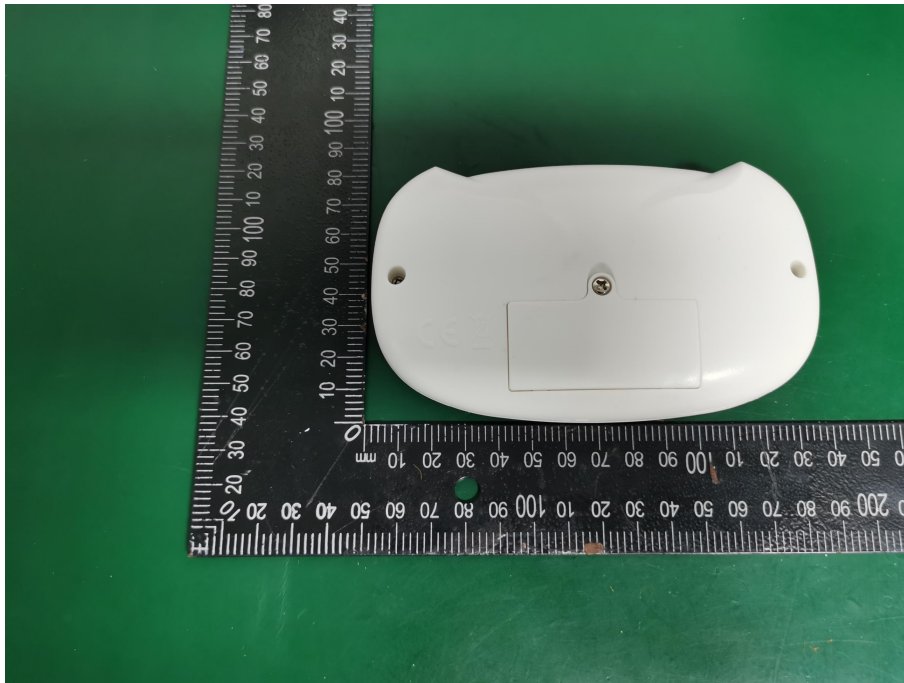
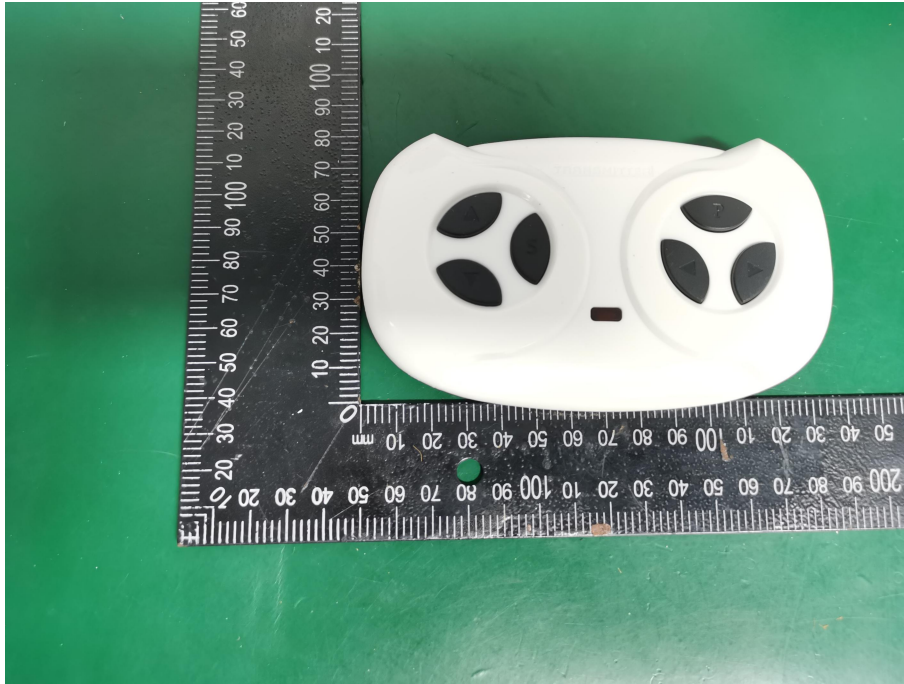



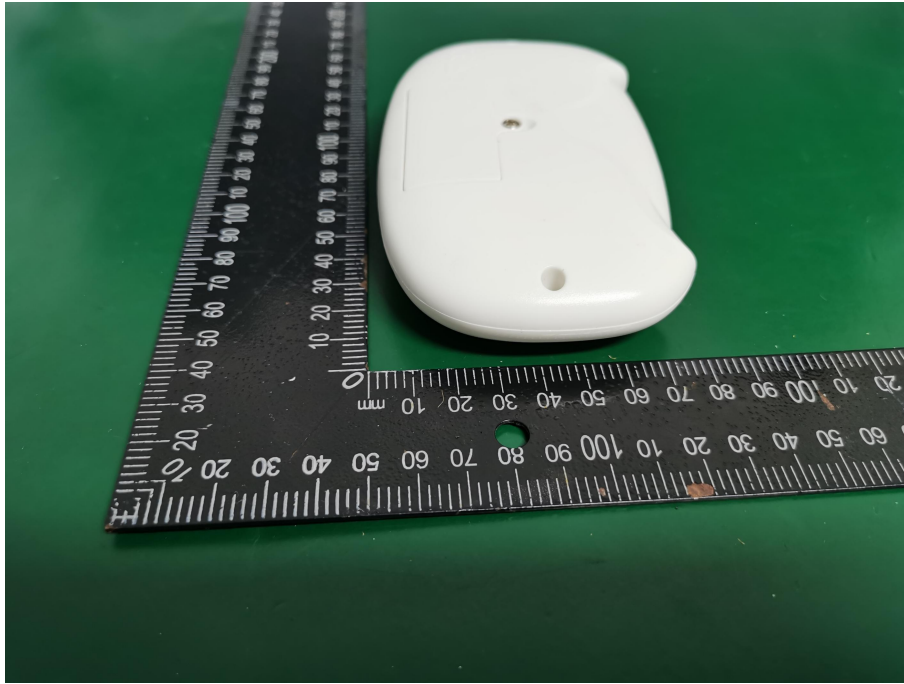

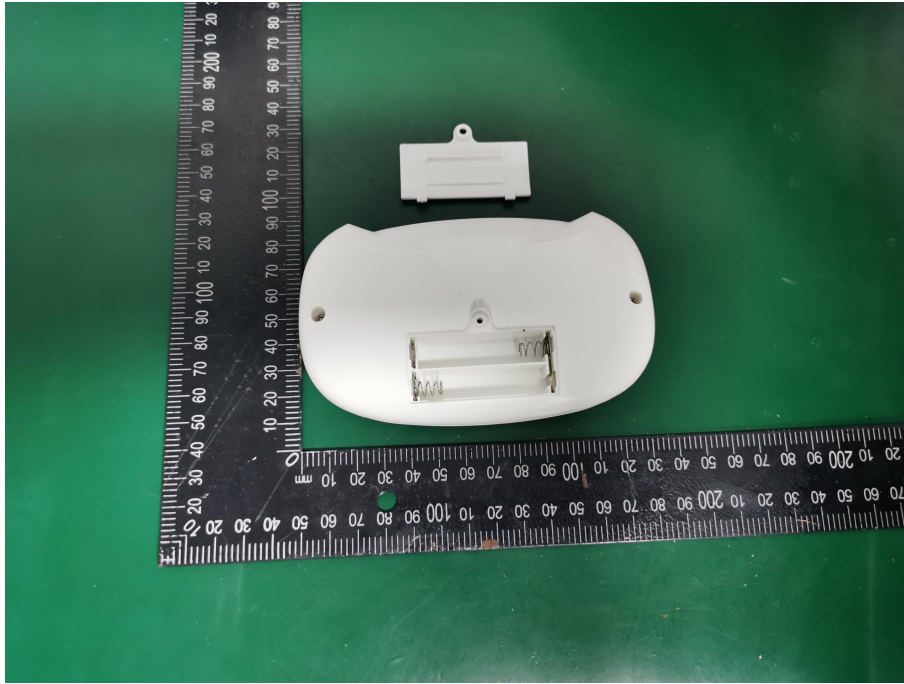

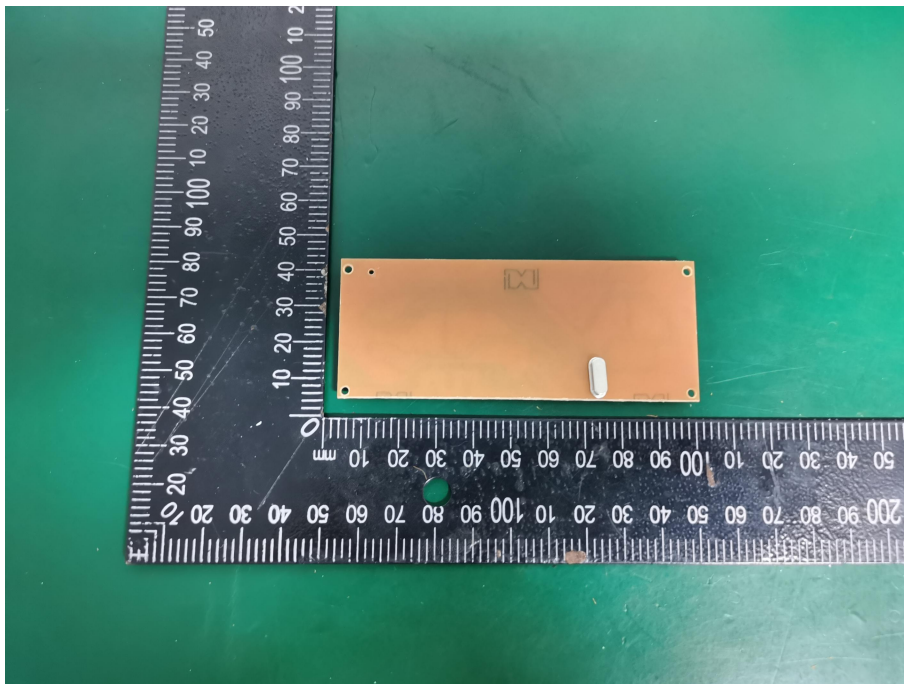
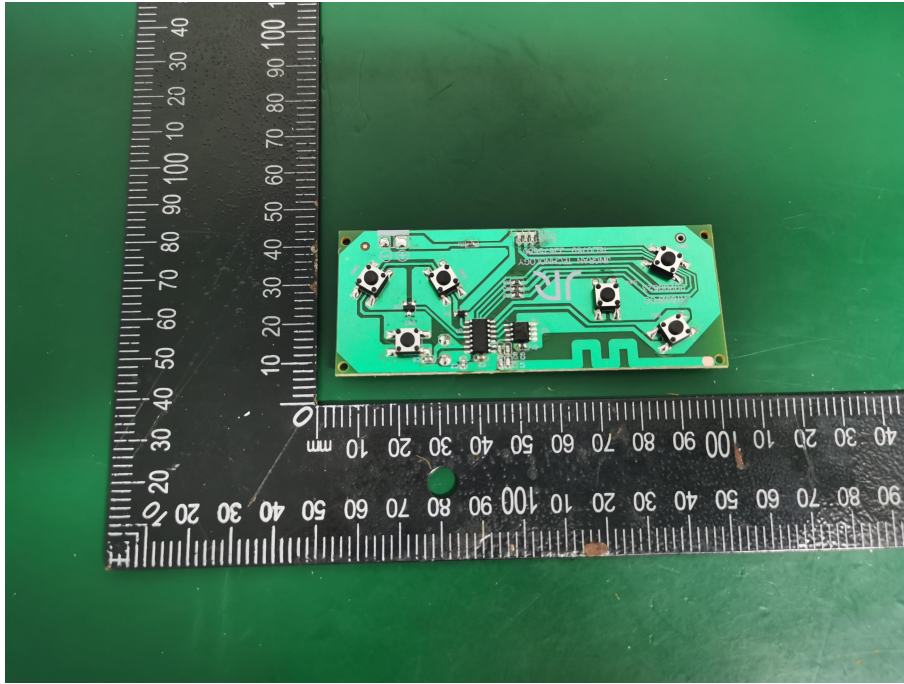

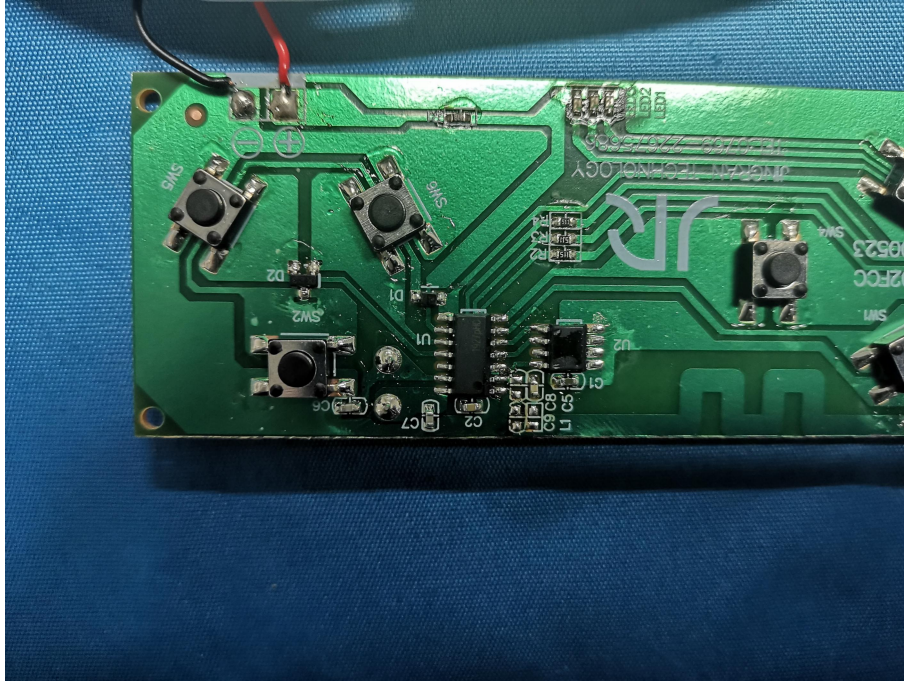

End of Report